

3 TYPICAL GABLE END DETAIL  
NO SCALE

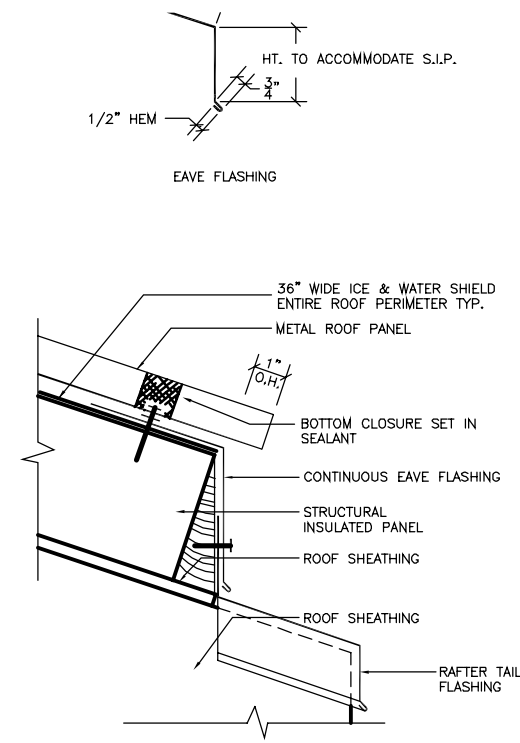

4 TYPICAL EAVE DETAIL  
NO SCALE

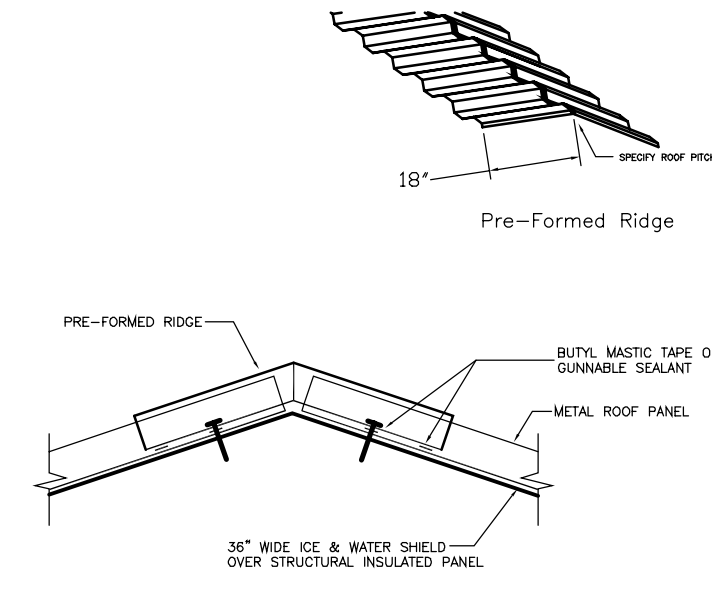

5 TYPICAL RIDGE DETAIL  
NO SCALE

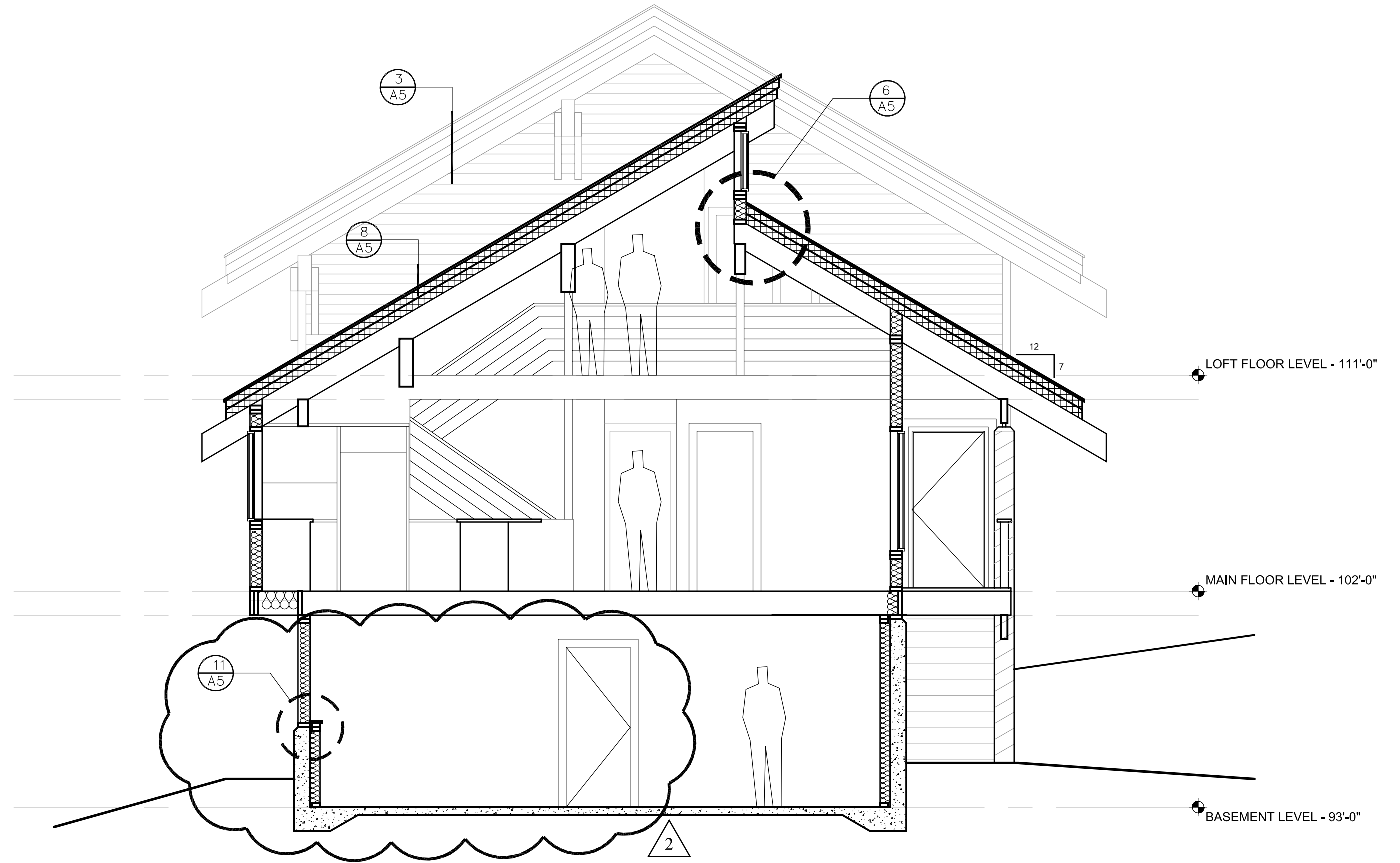

1 CROSS SECTION  
1/4" = 1'-0"

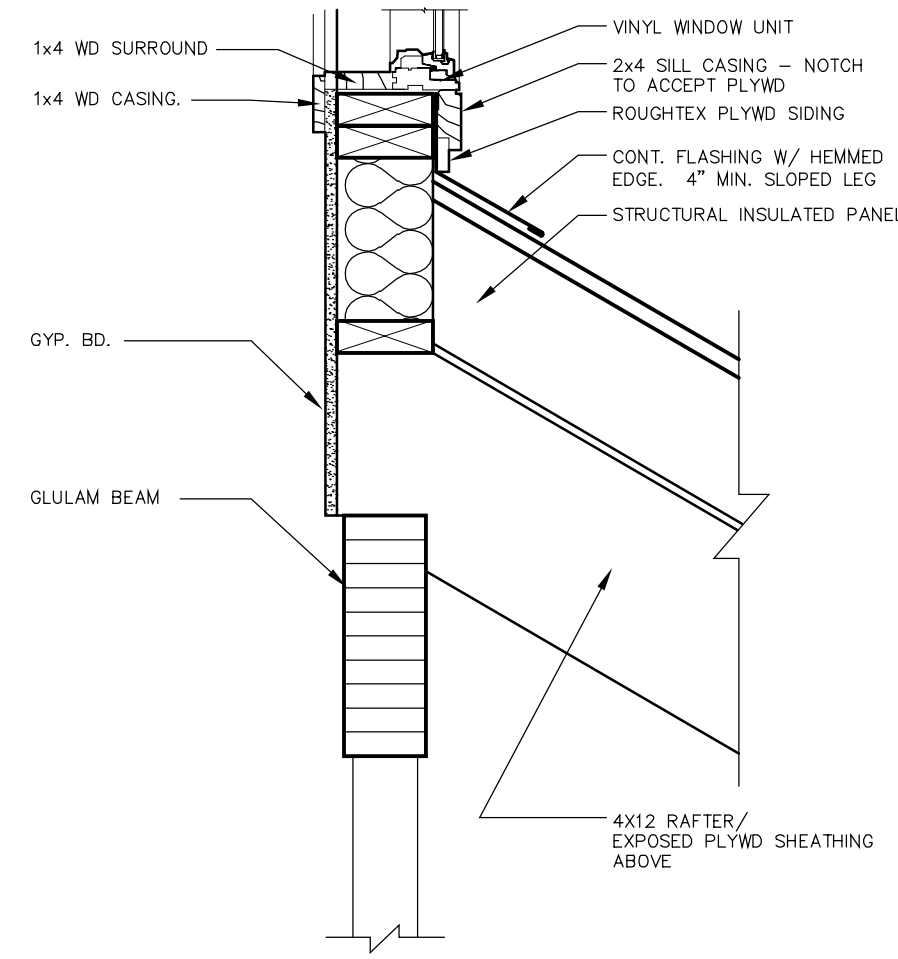

6 ROOF @ CLERESTORY SILL DETAIL  
NO SCALE

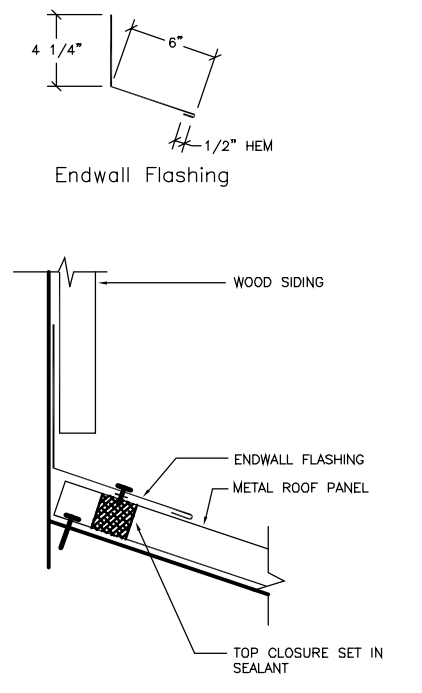

7 TYPICAL ROOF TO END WALL DETAIL  
NO SCALE

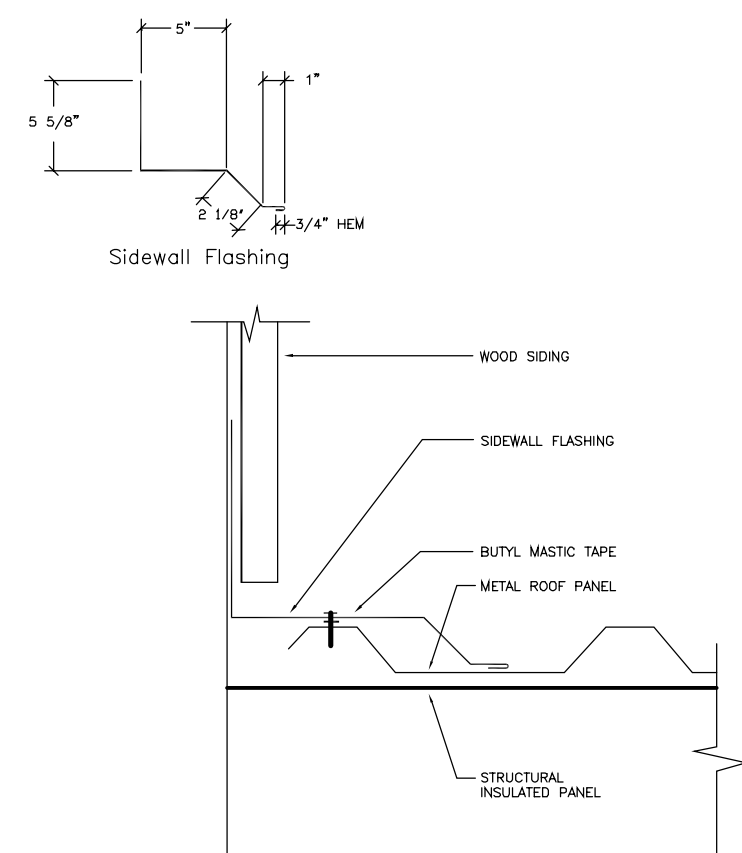

8 TYPICAL ROOF TO SIDEWALL DETAIL  
NO SCALE

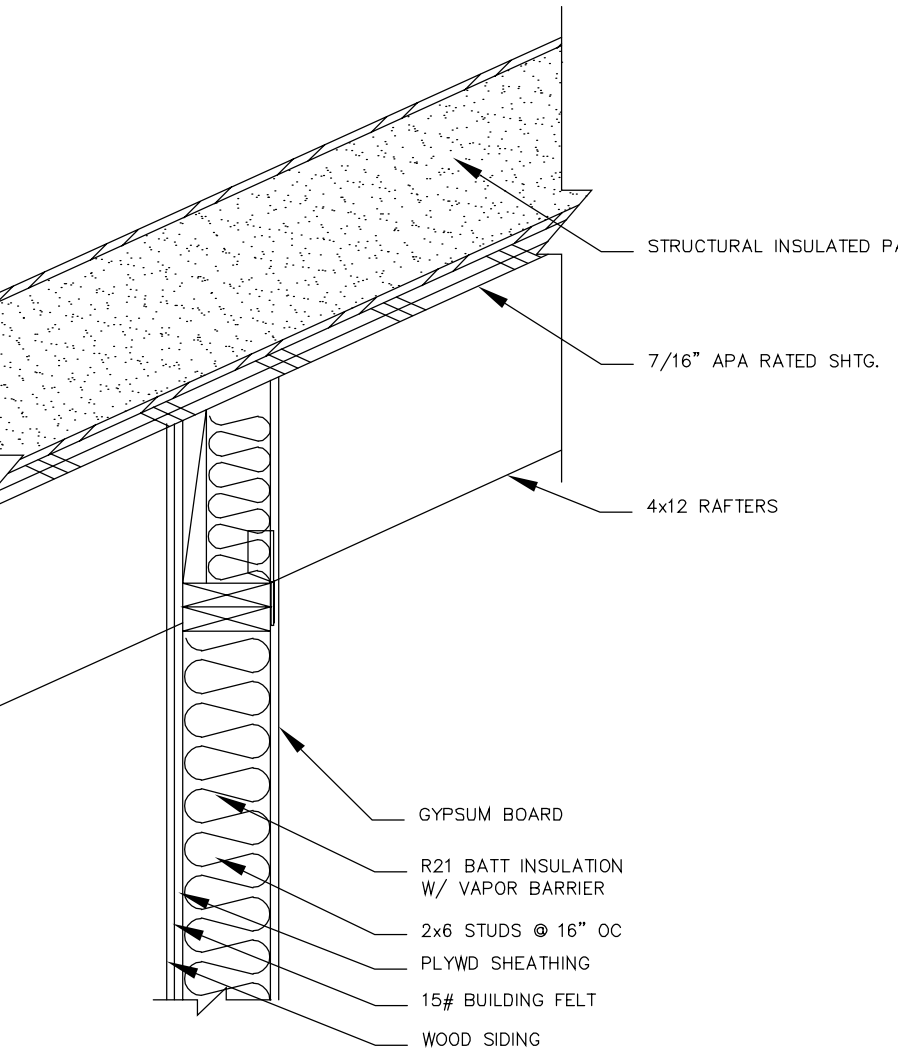

9 ROOF @ EXTERIOR WALL TOP PLATE  
NO SCALE

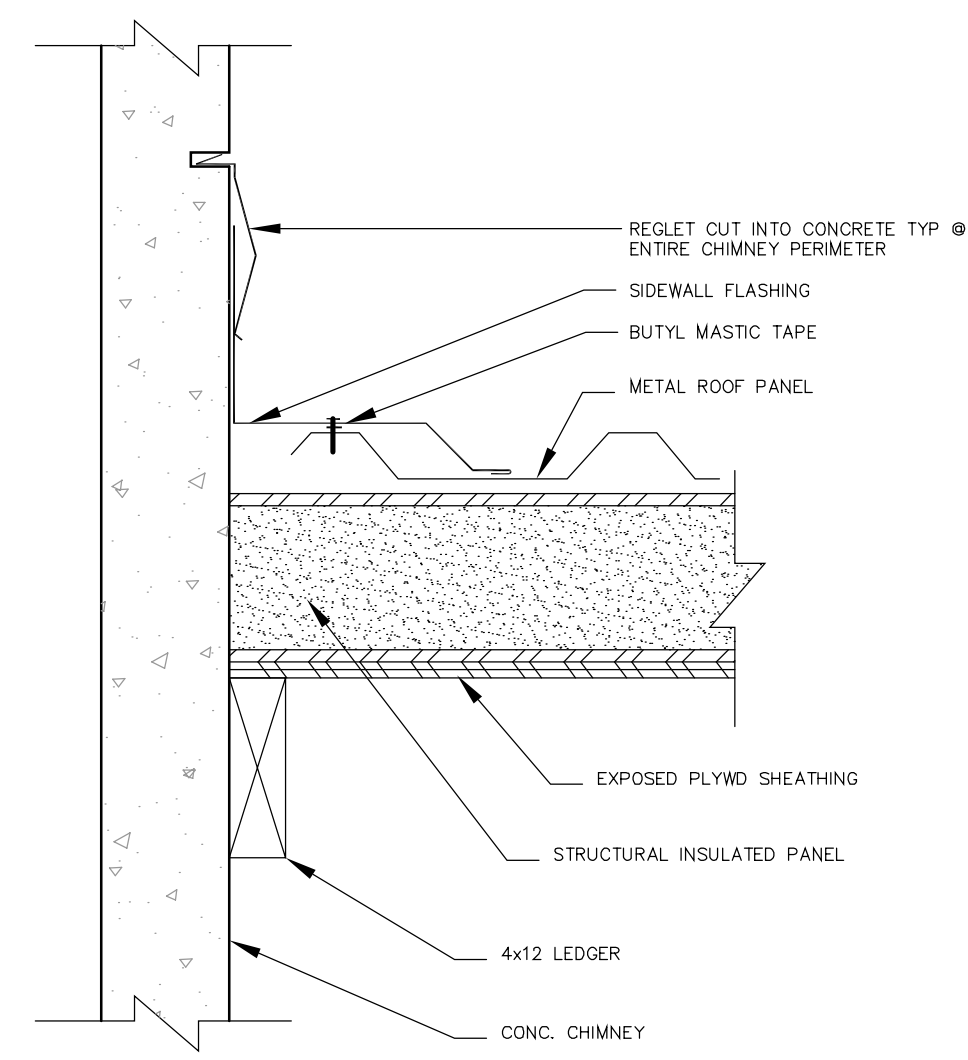

10 ROOF @ CHIMNEY DETAIL  
NO SCALE

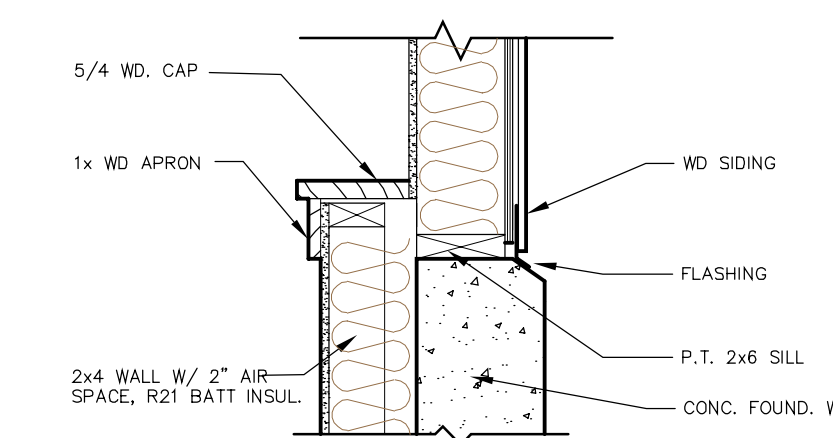

11 FOUNDATION TO STUD WALL DETAIL  
NO SCALE

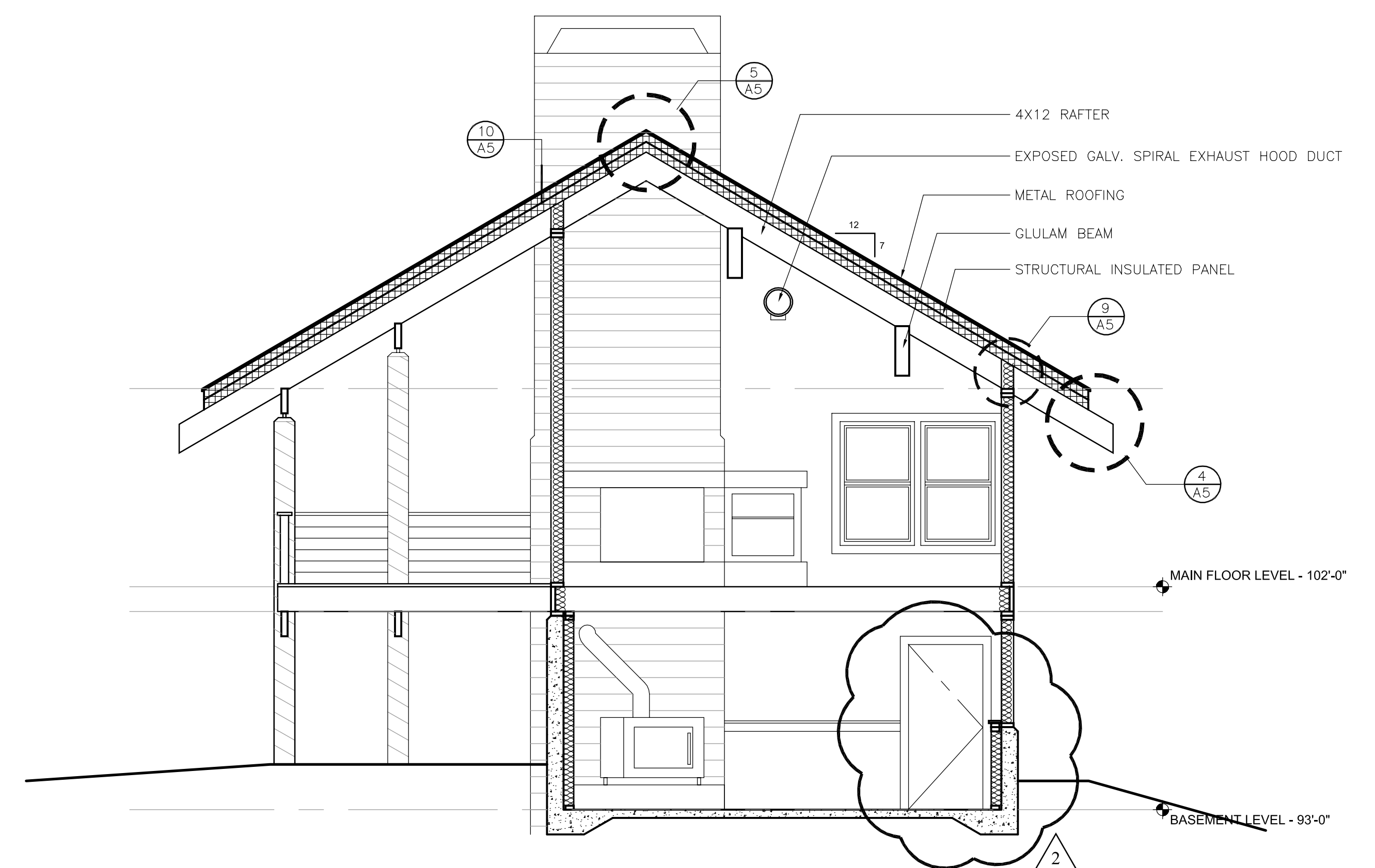

2 CROSS SECTION  
1/4" = 1'-0"

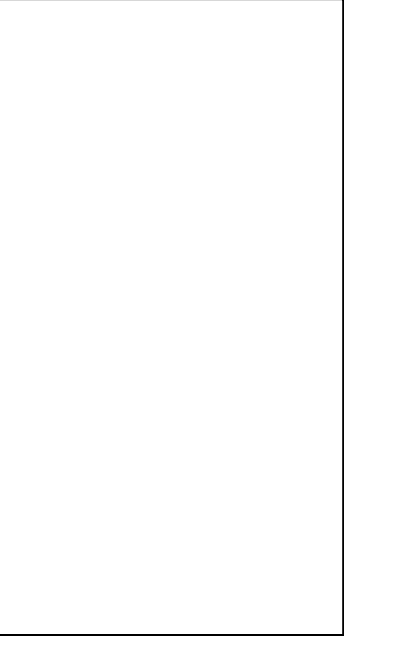
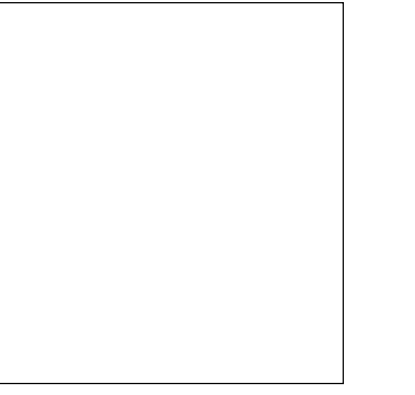
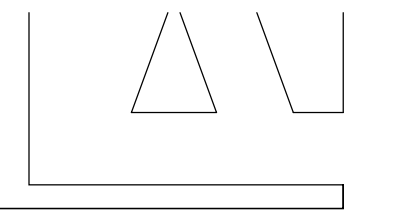

SANDLER / SROFE MOUNTAIN DWELLING  
GOVERNMENT CAMP, OREGON  
BUILDING SECTIONS / DETAILS

REVISED: 02.28.05  
REVISED: 04.10.04  
DATE: 02.27.04  
CHECK:  
DRAWN BY: TLA  
PROJECT #: mndwlg

SHEET:  
A5